



STRUCTURAL CALCULATION

Solar Panel Array	3x9 5d
Calculation Standard	ASCE7-10/AISC360
Date	2024/1/19

CONTENTS

1.Basic information and design standards.....	3
1.1 Standard code.....	3
1.2 Design condition and technical parameters.....	3
2.Load calculation.....	3
2.1 Design structural.....	3
2.1.1 Sketch of bracket.....	3
2.1.2 Structure properties.....	4
2.2 Load calculation.....	6
2.2.1 Dead load.....	6
2.2.2 Snow load	6
2.2.3 Wind load.....	6
2.2.4 Load combinaton.....	9
2.3 Strength Calculation.....	9
2.3.1 Load diagram	10
2.3.2 Structural calculation	11

1. Basic information and design standards

1.1 Standard code

- ASCE 7-10/AISC360

1.2 Design condition and technical parameters

- Solar Panel: L1722*W1134*H30/35 400W 20.8Kg
- Layout: 3x9
- Installation angle: 5°
- Span: 3437*5100 mm
- Calculation ground clearance: 2676 mm
- Exposure category: B
- Wind speed in design: $V=58.1$ m/s (provided by the client)
- Load of snow accumulation on the ground: $S_o=1.44$ KN/m²
- Design working life of structure: 25years
- Design Software :sap2000

2. Load calculation

2.1 Design structural

2.1.1 Sketch of bracket

- Layout

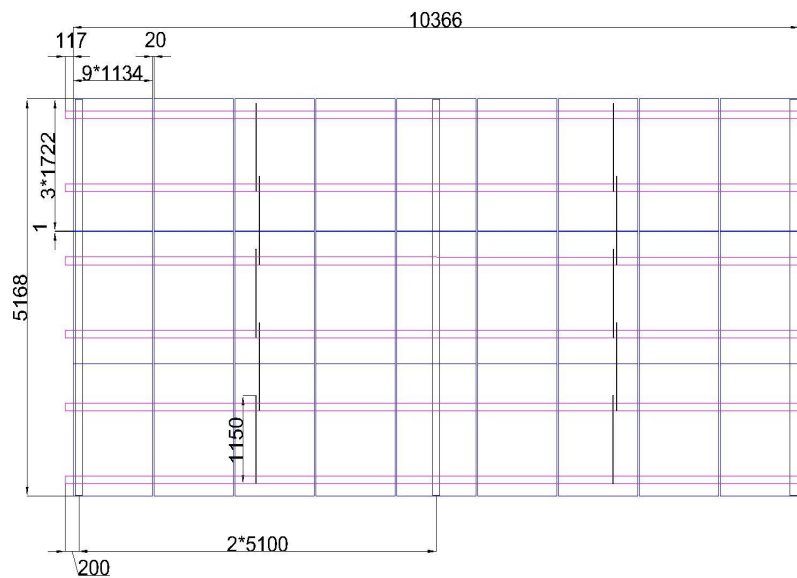

- Side view

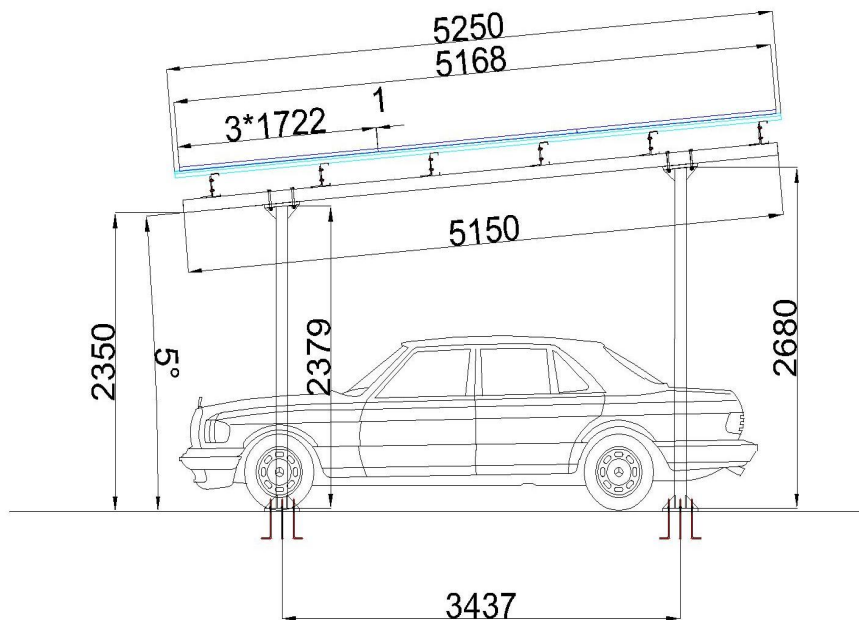

2.1.2 Structure properties

a. Mount rail

C180x90x20x3.0

Q235B

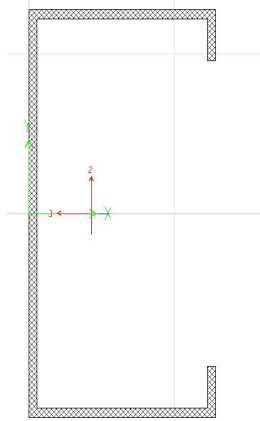

Property Data			
Section Name		C180x90x20x3.0	
Properties			
Cross-section (axial) area	1164.	Section modulus about 3 axis	68642.58
Moment of Inertia about 3 axis	6177832	Section modulus about 2 axis	20742.238
Moment of Inertia about 2 axis	1258968.3	Plastic modulus about 3 axis	78504.
Product of Inertia about 2-3	0.	Plastic modulus about 2 axis	31944.
Shear area in 2 direction	564.0354	Radius of Gyration about 3 axis	72.852
Shear area in 3 direction	513.6847	Radius of Gyration about 2 axis	32.8875
Torsional constant	3517.0032	Shear Center Eccentricity (x3)	0.

b. Welded beam

100*100*4.5

Q235B

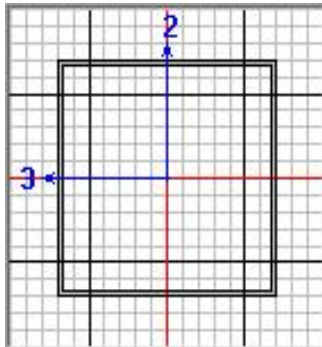

Property Data			
Section Name		100x100x4.5	
Properties			
Cross-section (axial) area	1719.	Section modulus about 3 axis	52375.07
Moment of Inertia about 3 axis	2618753.3	Section modulus about 2 axis	52375.07
Moment of Inertia about 2 axis	2618753.3	Plastic modulus about 3 axis	61607.25
Product of Inertia about 2-3	0.	Plastic modulus about 2 axis	61607.25
Shear area in 2 direction	900.	Radius of Gyration about 3 axis	39.031
Shear area in 3 direction	900.	Radius of Gyration about 2 axis	39.031
Torsional constant	3919427.	Shear Center Eccentricity (x3)	0.

c. Welded pile

100*100*2.75

Q235B

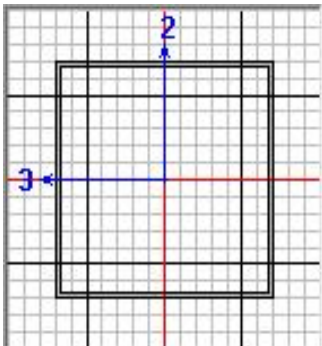

Property Data			
Section Name		100x100x2.75	
Properties			
Cross-section (axial) area	1069.75	Section modulus about 3 axis	33751.06
Moment of Inertia about 3 axis	1687552.9	Section modulus about 2 axis	33751.06
Moment of Inertia about 2 axis	1687552.9	Plastic modulus about 3 axis	39022.84
Product of Inertia about 2-3	0.	Plastic modulus about 2 axis	39022.84
Shear area in 2 direction	550.	Radius of Gyration about 3 axis	39.718
Shear area in 3 direction	550.	Radius of Gyration about 2 axis	39.718
Torsional constant	2529306.9	Shear Center Eccentricity (x3)	0.

d. BIPV rail

AL6005-T5

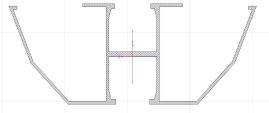

Property Data			
Section Name		BIPV rail	
Properties:			
Cross-section (axial) area	443.1572	Section modulus about 3 axis	4374.4883
Moment of Inertia about 3 axis	106032.49	Section modulus about 2 axis	7166.4205
Moment of Inertia about 2 axis	442265.	Plastic modulus about 3 axis	5842.9982
Product of Inertia about 2-3	-2.7104	Plastic modulus about 2 axis	11444.787
Shear area in 2 direction	278.3223	Radius of Gyration about 3 axis	15.4682
Shear area in 3 direction	240.0673	Radius of Gyration about 2 axis	31.5909
Torsional constant	394.5565	Shear Center Eccentricity (x3)	0.

e. Steel rod

φ10

Q235B

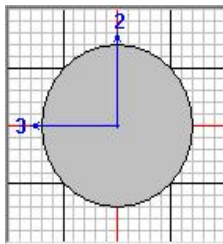

Property Data			
Section Name		Steel rod	
Properties:			
Cross-section (axial) area	78.5398	Section modulus about 3 axis	98.1748
Moment of Inertia about 3 axis	490.8739	Section modulus about 2 axis	98.1748
Moment of Inertia about 2 axis	490.8739	Plastic modulus about 3 axis	166.6667
Product of Inertia about 2-3	0.	Plastic modulus about 2 axis	166.6667
Shear area in 2 direction	70.6858	Radius of Gyration about 3 axis	2.5
Shear area in 3 direction	70.6858	Radius of Gyration about 2 axis	2.5
Torsional constant	981.7477	Shear Center Eccentricity (x3)	0.

2.2 Load calculation

2.2.1 Dead load

- Solar Panel;

Dead-weight of panel $G_1=20.8\text{kg} \approx$

0.204 KN

Standard load of panel: $G_1/m^2 = 0.204\text{KN}/(1.722 \times 1.134) = 104 \text{ N/m}^2$

2.2.2 Snow load

(1) Flat Roof Snow Loads, p_f

- a. Ground snow load, P_g

$P_g = 1440 \text{ N/m}^2$

- b. Exposure Factor, $C_e=0.9$

The value for C_e shall be determined from Table 7-

Table 7-2 Exposure Factor, C_e

Terrain Category	Exposure of Roof ^a		
	Fully Exposed	Partially Exposed	Sheltered
B (see Section 26.7)	0.9	1.0	1.2
C (see Section 26.7)	0.9	1.0	1.1
D (see Section 26.7)	0.8	0.9	1.0
Above the treeline in windswept mountainous areas.	0.7	0.8	N/A
In Alaska, in areas where trees do not exist within a 2-mile (3-km) radius of the site.	0.7	0.8	N/A

- c. Thermal Factor, $C_t= 1.2$

The value for C_t shall be determined from Table 7-

Table 7-3 Thermal Factor, C_t

Thermal Condition ^a	C_t
All structures except as indicated below	1.0
Structures kept just above freezing and others with cold, ventilated roofs in which the thermal resistance (R-value) between the ventilated space and the heated space exceeds $25 \text{ }^\circ\text{F} \times h \times \text{ft}^2/\text{Btu}$ ($4.4 \text{ K} \times \text{m}^2/\text{W}$).	1.1
Unheated and open air structures	1.2
Structures intentionally kept below freezing	1.3
Continuously heated greenhouses ^b with a roof having a thermal resistance (R-value) less than $2.0 \text{ }^\circ\text{F} \times h \times \text{ft}^2/\text{Btu}$ ($0.4 \text{ K} \times \text{m}^2/\text{W}$)	0.85

- d. Importance Factor, $I_s=1$

The value for I_s shall be determined from Table 1.5-2 based on the Risk Category from

Risk Category from Table 1.5-1	Snow Importance Factor, I_s	Ice Importance Factor—Thickness, I_i	Ice Importance Factor—Wind, I_w	Seismic Importance Factor, I_s
I	0.80	0.80	1.00	1.00
II	1.00	1.00	1.00	1.00
III	1.10	1.25	1.00	1.25
IV	1.20	1.25	1.00	1.50

^aThe component importance factor I_s applies to earthquake loads. It is not included in this table because it is dependent on the importance of

Then, The flat roof snow load, p_f , shall be calculated in lb/ft^2 (kN/m^2) using the following formul

$$P_f = 0.7 C_e C_t I_s P_g = 1088.64 \text{ N/m}^2 \quad (7.3-1)$$

(2) Sloped Roof Snow Loads, p_s

The sloped roof (balanced) snow load, p_s , shall be obtained by multiplying the flat roof snow load, p_f , by the roof slope fact

$$P_s = C_s P_f \quad (7.4-1)$$

$C_s = 1.00$

$$\text{Then, } P_s = C_s P_f = 1088.64 \text{ N/m}^2$$

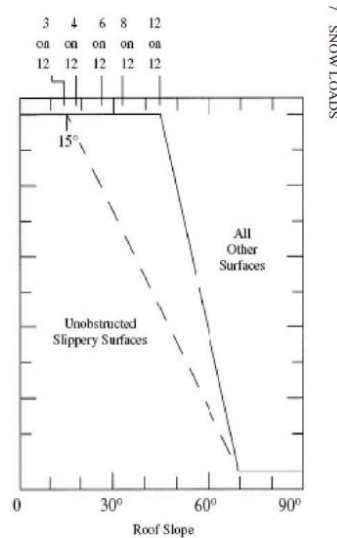

7-2c: Cold roofs with $C = 1.2$ or larger

2.2.3 Wind load

- Based Wind Speed 58.1 m/s
- Exposure category: B
- Installation angle= 5°

Design wind load for open buildings with monoslope, pitched, or troughed free module

$$P = qhGCN \quad (27.4-3)$$

Where:

qh = velocity pressure evaluated at mean roof height h using the exposure as defined in Section 26.7.3 that results in the highest wind loads for any wind direction at the site

$G = 0.85$ (gust-effect factor from Section 26.9)

CN = net pressure coefficient determined from Figs. 27.4-4 through 27.4-7

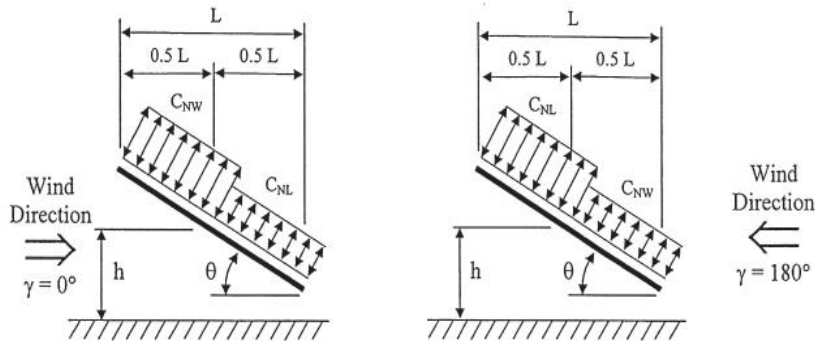

Roof Angle θ	Load Case	Wind Direction, $\gamma = 0^\circ$				Wind Direction, $\gamma = 180^\circ$			
		Clear Wind Flow		Obstructed Wind Flow		Clear Wind Flow		Obstructed Wind Flow	
		C_{NW}	C_{NL}	C_{NW}	C_{NL}	C_{NW}	C_{NL}	C_{NW}	C_{NL}
0°	A	1.2	0.3	-0.5	-1.2	1.2	0.3	-0.5	-1.2
	B	-1.1	-0.1	-1.1	-0.6	-1.1	-0.1	-1.1	-0.6
7.5°	A	-0.6	-1	-1	-1.5	0.9	1.5	-0.2	-1.2
	B	-1.4	0	-1.7	-0.8	1.6	0.3	0.8	-0.3
15°	A	-0.9	-1.3	-1.1	-1.5	1.3	1.6	0.4	-1.1
	B	-1.9	0	-2.1	-0.6	1.8	0.6	1.2	-0.3
22.5°	A	-1.5	-1.6	-1.5	-1.7	1.7	1.8	0.5	-1
	B	-2.4	-0.3	-2.3	-0.9	2.2	0.7	1.3	0
30°	A	-1.8	-1.8	-1.5	-1.8	2.1	2.1	0.6	-1
	B	-2.5	-0.5	-2.3	-1.1	2.6	1	1.6	0.1
37.5°	A	-1.8	-1.8	-1.5	-1.8	2.1	2.2	0.7	-0.9
	B	-2.4	-0.6	-2.2	-1.1	2.7	1.1	1.9	0.3
45°	A	-1.6	-1.8	-1.3	-1.8	2.2	2.5	0.8	-0.9
	B	-2.3	-0.7	-1.9	-1.2	2.6	1.4	2.1	0.4

Notes:

- C_{NW} and C_{NL} denote net pressures (contributions from top and bottom surfaces) for windward and leeward half of roof surfaces, respectively.
- Clear wind flow denotes relatively unobstructed wind flow with blockage less than or equal to 50%. Obstructed wind flow denotes objects below roof inhibiting wind flow (>50% blockage).
- For values of θ between 7.5° and 45° , linear interpolation is permitted. For values of θ less than 7.5° , use load coefficients for 0° .
- Plus and minus signs signify pressures acting towards and away from the top roof surface, respectively.
- All load cases shown for each roof angle shall be investigated.
- Notation:
 L : horizontal dimension of roof, measured in the along wind direction, ft. (m)
 h : mean roof height, ft. (m)
 γ : direction of wind, degrees
 θ : angle of plane of roof from horizontal, degrees

Then, CN (Net pressure coefficient)

Roof Angle	Load case	Wind Direction, $\gamma = 0^\circ$		Wind Direction, $\gamma = 180^\circ$	
		Clear Wind Flow		Clear Wind Flow	
		CNW	CNL	CNW	CNL
5	A	1.20	0.30	1.20	0.30
	B	-1.10	-0.10	-1.10	-0.10

Velocity pressure, q_z , evaluated at height z shall be calculated by the following equation:

$$q_z = 0.613K_zK_{zt}K_dV^2 \quad (27.3-1)$$

Where:

K_d = wind directionality factor, see Section 26.6

K_z = velocity pressure exposure coefficient, see Section 27.3.1

K_{zt} = topographic factor defined, see Section 26.8.2

$V = 58.1$ m/s basic wind speed, see Section 26.5

a. Wind Directionality Factor, K_d

Structure Type	Directionality Factor K_d^*
Buildings Main Wind Force Resisting System Components and Cladding	0.85 0.85
Arched Roofs	0.85
Chimneys, Tanks, and Similar Structures Square Hexagonal Round	0.90 0.95 0.95
Solid Freestanding Walls and Solid Freestanding and Attached Signs	0.85
Open Signs and Lattice Framework	0.85
Trussed Towers Triangular, square, rectangular All other cross sections	0.85 0.95

*Directionality Factor K_d has been calibrated with combinations of loads specified in Chapter 2. This factor shall only be applied when used in conjunction with load combinations specified in Sections 2.3 and 2.4.

Then, $K_d = 0.85$

b. Topographic Factor

The wind speed-up effect shall be included in the calculation of design wind loads by using the factor K_{zt} :

$$K_{zt} = (1 + K_1K_2K_3)^2 \quad (26.8-1)$$

where K_1 , K_2 , and K_3 are given in Fig. 26.8-1.

If site conditions and locations of structures do not meet all the conditions specified in Section 26.8.1 then,

$$K_{zt} = 1$$

c. Velocity Pressure Exposure Coefficient

Based on the exposure category determined in Section 26.7.3, a velocity pressure exposure coefficient K_z or K_h , as applicable, shall be determined from Table 27.3-1. For a site located in a transition zone between exposure categories that is near to a change in ground surface roughness, intermediate values of K_z or K_h , between those shown in Table 27.3-1 are permitted provided that they are determined by a rational analysis method defined in the recognized literature.

Height above ground level, z		Exposure		
		B	C	D
ft	(m)			
0-15	(0-4.6)	0.57	0.85	1.03
20	(6.1)	0.62	0.90	1.08
25	(7.6)	0.66	0.94	1.12
30	(9.1)	0.70	0.98	1.16
40	(12.2)	0.76	1.04	1.22
50	(15.2)	0.81	1.09	1.27
60	(18)	0.85	1.13	1.31
70	(21.3)	0.89	1.17	1.34
80	(24.4)	0.93	1.21	1.38
90	(27.4)	0.96	1.24	1.40
100	(30.5)	0.99	1.26	1.43
120	(36.6)	1.04	1.31	1.48
140	(42.7)	1.09	1.36	1.52

Notes:

1. The velocity pressure exposure coefficient K_z may be determined from the following formula:

$$\text{For } 15 \text{ ft.} \leq z \leq z_g$$

$$K_z = 2.01 (z/z_g)^{2/\alpha}$$

$$\text{For } z < 15 \text{ ft.}$$

$$K_z = 2.01 (15/z_g)^{2/\alpha}$$

2. α and z_g are tabulated in Table 26.9.1.
3. Linear interpolation for intermediate values of height z is acceptable.
4. Exposure categories are defined in Section 26.7.

Than, $Kz = 0.85$
 So, $qz = 0.613KzKztKdV^2 = 1495.03 \text{ N/m}^2$

NET DESIGN PRESSURE (p)
 $P = qh * G * CN$

Roof Angle	Load case	Wind Direction, $\gamma = 0^\circ$		Wind Direction, $\gamma = 180^\circ$	
		Clear Wind Flow		Clear Wind Flow	
		PNW	PNL	PNW	PNL
5	A	1.73	0.43	1.73	0.43
	B	-1.59	-0.14	-1.59	-0.14

CASE A

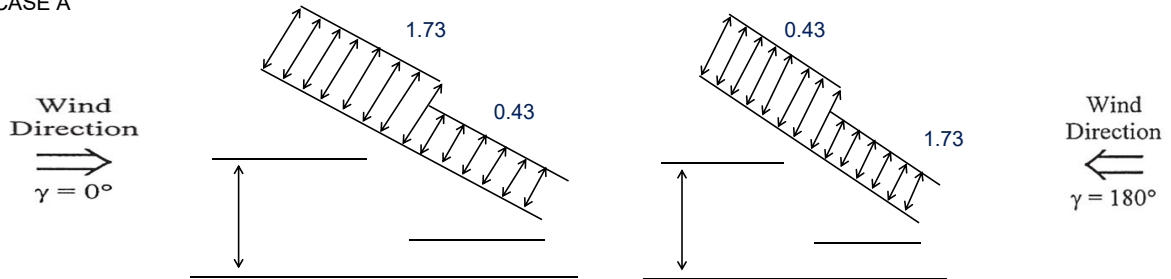

CASE B

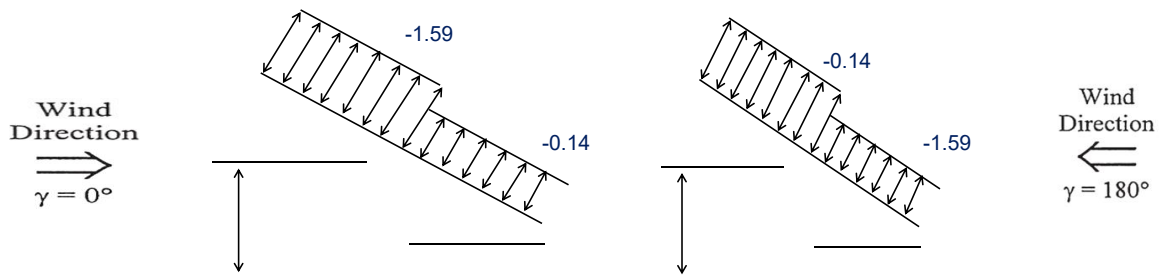

2.2.4 Load combination

Load and Resistance Factor Design (LRFD)

- 1.4D
 - 1.2D+1.6S+0.5W
 - 1.2D+1.0W+0.5S
 - 0.9D+1.0W
- G: Dead load
 S: Snow load
 W: Wind load

2.3 Strength Calculation

Dead load $G = 0.12 \text{ N/mm}$
 Wind load $W =$

Roof Angle	Load case	Wind Direction, $\gamma = 0^\circ$		Wind Direction, $\gamma = 180^\circ$	
		Clear Wind Flow		Clear Wind Flow	
		PNW	PNL	PNW	PNL
5	A	1.73	0.43	1.73	0.43
	B	-1.59	-0.14	-1.59	-0.14

Snow load $S = 1.23 \text{ N/mm}$

2.3.1 Load diagram:
Dead load D:

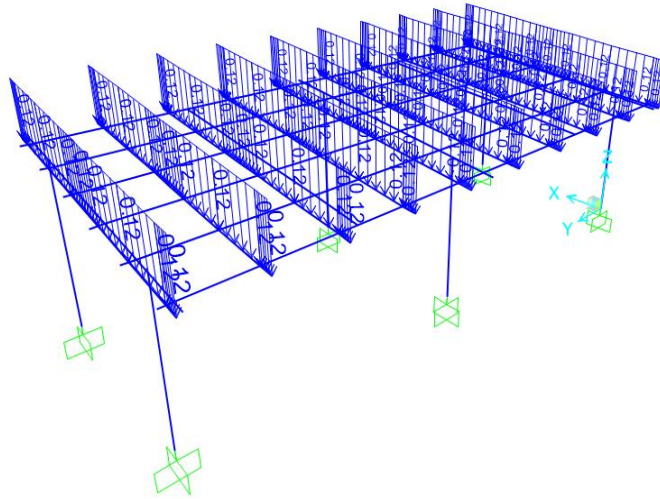

Wind load W:
CASE A
w+

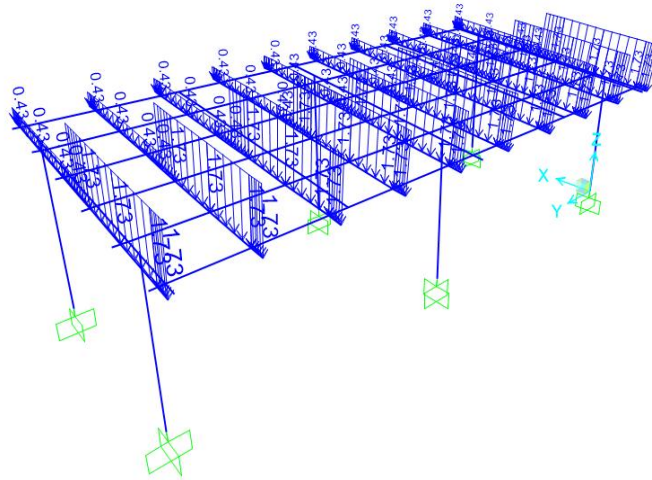

w-

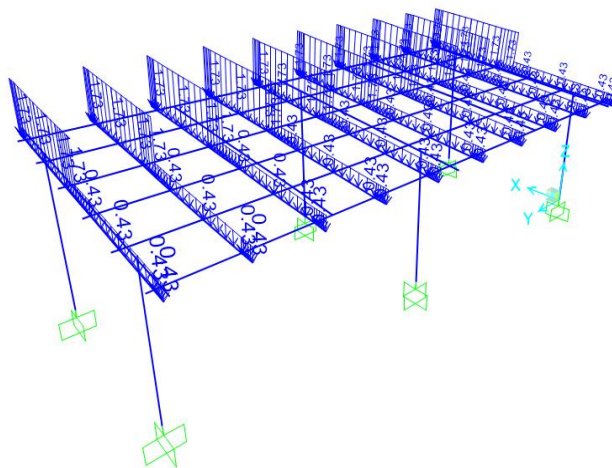

CASE B
w+

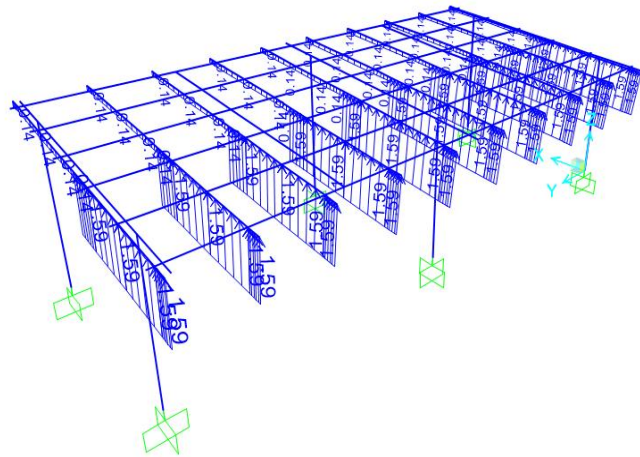

w-

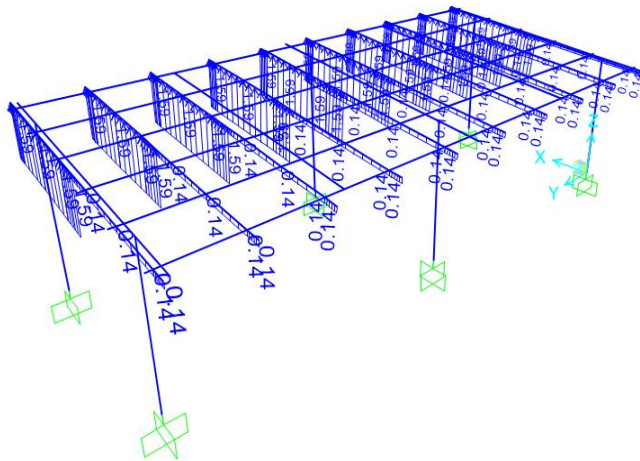

Snow load S:

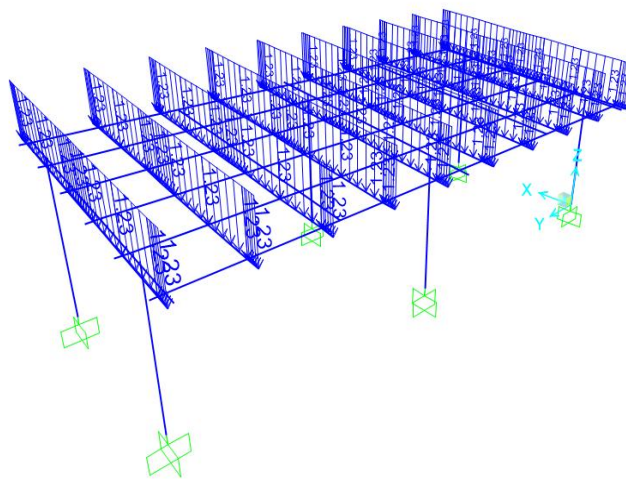

2.3.2 Structural calculation

a.Design utility ratio

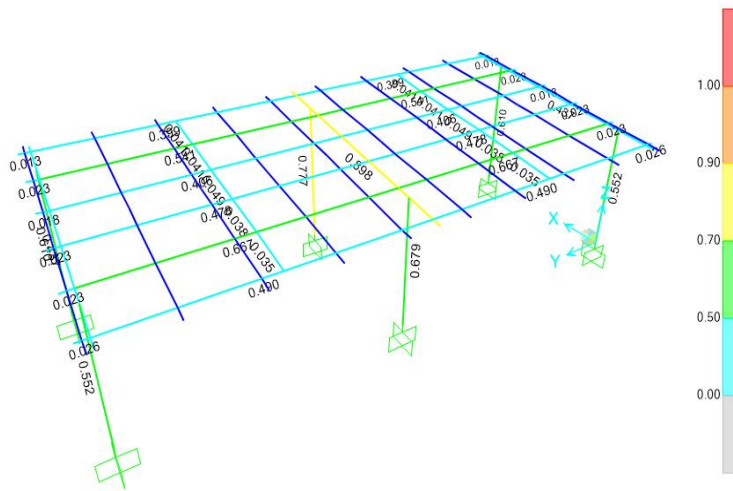

Items	ratio
Mount rail	0.667
Welded beam	0.898
Welded pile	0.777
Steel rod	0.049

Item	BIPV rail
Axial P, N	15.770
Moment M2, N*m	93677.080
Moment M3, N*m	349202.480
$P \sigma_p = F/A, \text{Mpa}$	0.035
$M2 \sigma_y = M_y/W_y B, \text{Mpa}$	12.710
$M3 \sigma_z = M_x/W_x B, \text{Mpa}$	81.863
$[\sigma], \text{Mpa}$	240
Ratio	0.394
	ok

Note: ratio = Actual stress/Allowable stress

-----Failed ratio>1.0 ----- Passed ratio<1.0

b.Deflection ratio

Steel Stress Check Information (AISC360-05/IBC2006)

Frame ID: 39 Analysis Section: C180x90x20x3.0
 Design Code: AISC360-05/IBC2006 Design Section: C180x90x20x3.0

COMBO ID	STATION LOC	DEFLECTION RATIO
(挠度) G+S	1346.33	0.313
(挠度) G+S	1731.00	0.370
(挠度) G+S	1731.00	0.370
(挠度) G+S	2140.50	0.407
(挠度) G+S	2550.00	0.419
(挠度) G+S	2550.00	0.419

Modify/Show Overwrites: Overwrites | Display Details for Selected Item: Details | Envelope | Display Complete Details: Tabular Data

Strength Deflection OK Cancel Table Format File

Note: -----Failed ratio>1.0 ----- Passed ratio<1.0

c.Reaction force of foundation

Positive Force

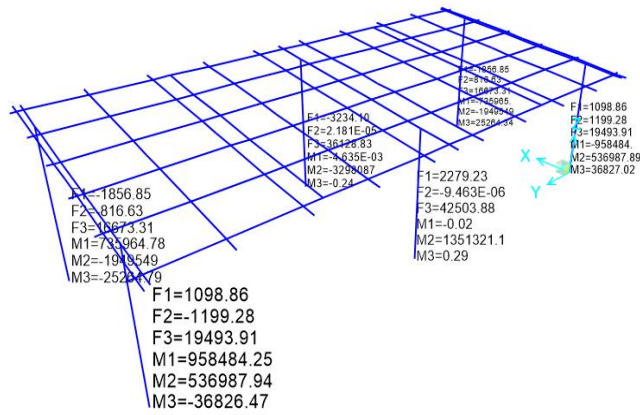

Maximum vertical force FV1= 36128.83 N/1 base
 Maximum horizontal force FH1= 3234.1 N/1 base

Negative Force

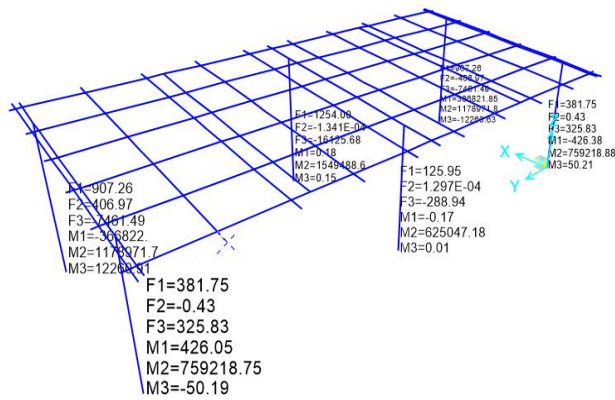

Maximum vertical force FV1= 16125.68 N/1 base
 Maximum horizontal force FH1= 1254 N/1 base